

Product Type: Drywall Stud
Product Definition: 162S125-18 33ksi
CSI Code: 09.22.16.13

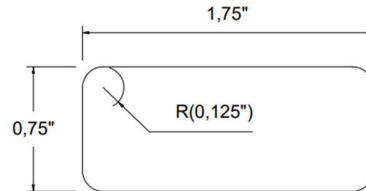
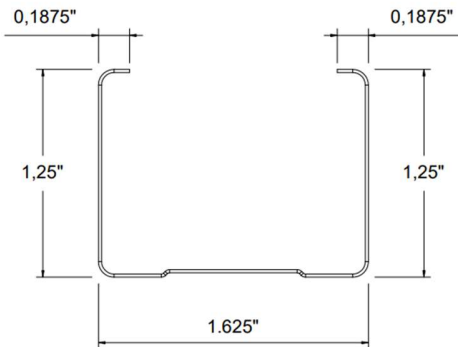

Punch Out

Profile Properties:

Web Depth	1,625 in	Yield Strength:	33 ksi
Flange Width	1,250 in	Unit Weight	0,27 lb/ft
Stiffening Lip	0,1875 in	Punchout Width / Length	0,75 in / 1,75 in
Design Thickness	0,0188 in	Finish	G40
Minimum Thickness	0,0179 in	Color Coding	None

Gross Section Properties:

Cross Sectional Area	Agross	0,0805 in ²
Moment of Inertia, x-axis	Ix	0,0380 in ⁴
Radius of Gyration, x-axis	rx	0,6869 in
Moment of Inertia, y-axis	Iy	0,0161 in ⁴
Radius of Gyration, y-axis	ry	0,4480 in

Torsional Properties:

St. Venant Torsion Constant	J x 1000	0,0095 in ⁴
Warping Constant	Cw	0,0092 in ⁶
Distance Between Shear Axis and Neutral Axis	x0	-1,029 in
Polar Radius of Gyration	r0	1,3161 in
Torsional Flexural Constant	β	0,3883
Limit of Unbraced Length	Lu	37,62 in

Effective Section Properties:

Effective Area	Aeff	0,0740 in ²
Effective Moment of Inertia for Deflection	Ixe	0,0337 in ⁴
Effective Section Modulus	Sxe	0,0388 in ³
Allowable Bending Moment	Ma	0,6777 in.k
Allowable Shear Force	Vag	309 lbs

Codes & Standards:

- Calculations are based on AISI S220-20 and AISI S100-16.
- Complies with IBC2021, ASTM C645, ASTM C754, ASTM A653, ASTM A1003, ASTM E72
- Intertek Certificate of Compliance No: COC-WHI23-37729201
- LEED / Sustainability Credits: Environmental Product Declaration S-P Code: S-P-00869

Limiting Heights, Non Composite (ft-in):

Profile	5 psf			7,5 psf			10 psf		
	L/120	L/240	L/360	L/120	L/240	L/360	L/120	L/240	L/360
12	9'-4"	7'-8"	6'-9"	7'-8"	6'-9"	5'-10"	6'-8"	6'-1"	5'-4"
16	8'-1"	7'-0"	6'-1"	6'-8"	6'-1"	5'-4"	5'-9"	5'-7"	4'-10"
24	6'-8"	6'-1"	5'-4"	5'-5"	5'-4"	4'-8"	4'-9"	4'-9"	4'-3"

- Heights are based on AISI S220-20 and AISI S100-16, using steel properties alone.
- Above listed Non-Composite Limiting Heights are applicable when the unbraced length is less than or equal to L_u . Heights are limited by moment, deflection and shear.

Limiting Heights, Composite – Fully Braced (ft-in):

Profile	5 psf			7,5 psf			10 psf		
	L/120	L/240	L/360	L/120	L/240	L/360	L/120	L/240	L/360
12	13'-0"	11'-1"	9'-10"	10'-8"	9'-8"	8'-7"	9'-3"	8'-9"	7'-9"
16	11'-3"	10'-1"	8'-11"	9'-3"	8'-9"	7'-9"	8'-0"	7'-11"	-
24	9'-3"	8'-9"	7'-9"	-	-	-	-	-	-

- The composite limiting heights are taken from ASTM C754-20 and based on a single layer of 5/8" Type X gypsum board to each stud flange.
- The gypsum board must be applied full height in the vertical orientation in accordance with ASTM C754 using minimum No. 6 Type S Drywall screws.
- Screws shall be spaced a maximum of 16 in on-center to framing members (including top & bottom track] spaced at 16 in or 12 in on-center.
- Screws shall be spaced a maximum of 12 in on-center to framing members (including top & bottom track] spaced at 24 in on-center.
- No fasteners are required for attaching the stud to the track except as detailed in ASTM C754.
- Stud end bearing must be a minimum of 1 inch.

